

P.O. Box 8  
Duchesne, UT 84021  
Phone 435 738-2453  
Fax 435 738-2620  
www.uintahmachine.com  
e-mail info@uintahmachine.com

---

---

## Uintah Machine Tool Trailers

Uintah Machine manufactures tool and mechanic trailers for transporting tools, welders and supplies. The two trailers shown below were customized to meet the needs of our customers. Every mine has different operating conditions, so send us a sketch or some parameters and we'll design one for you.

We take pride in our work. You can count on receiving the toughest, highest-quality, lowest-maintenance, tool

trailer around. Our customers have always been happy with our quality.

Uintah is happy to design and build a tool trailer to meet your specific needs. Contact us for a free quotation.

Our expertise is not limited to trailers alone. Visit our Web site at [www.uintahmachine.com](http://www.uintahmachine.com) for more information about our mining equipment and services.

Click on blue links to view drawings and photos

- Tool Trailer with pintle hitch ..... [TRAILER1.TCW](#)
- Mechanic's Trailer ..... [00457-01.TCW](#)
- Welder and Tool Trailer ..... [19363-01.TCW](#)  
[PHOTO 1](#)  
[PHOTO 2](#)

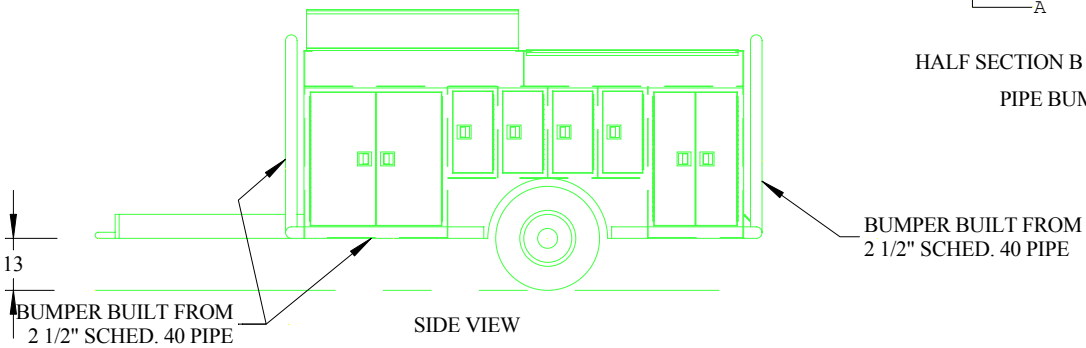
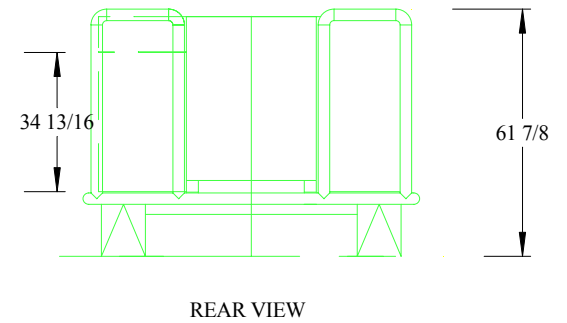
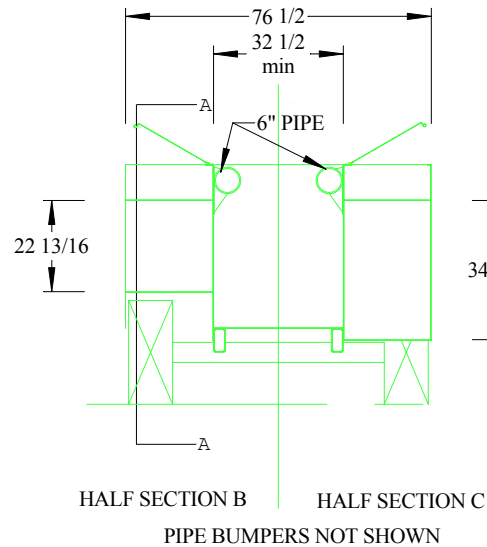
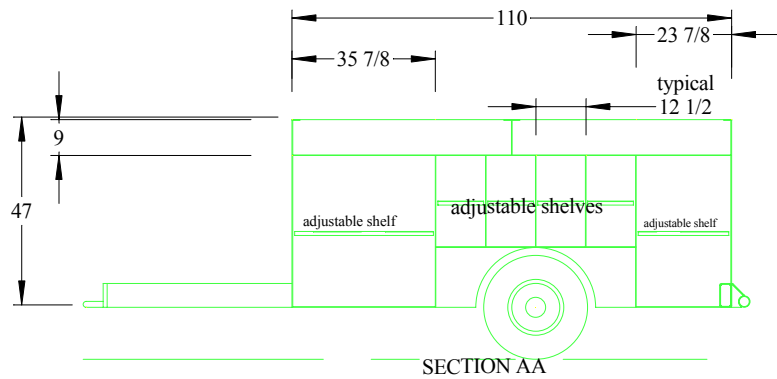
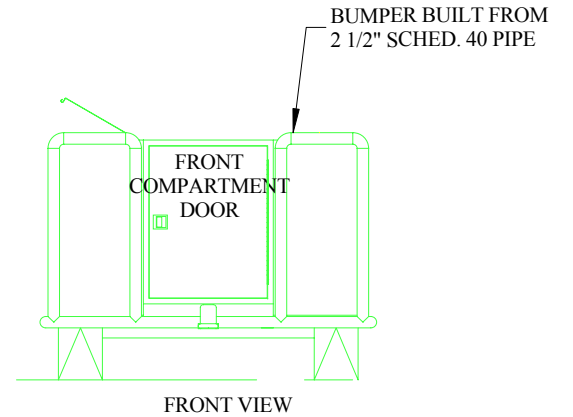
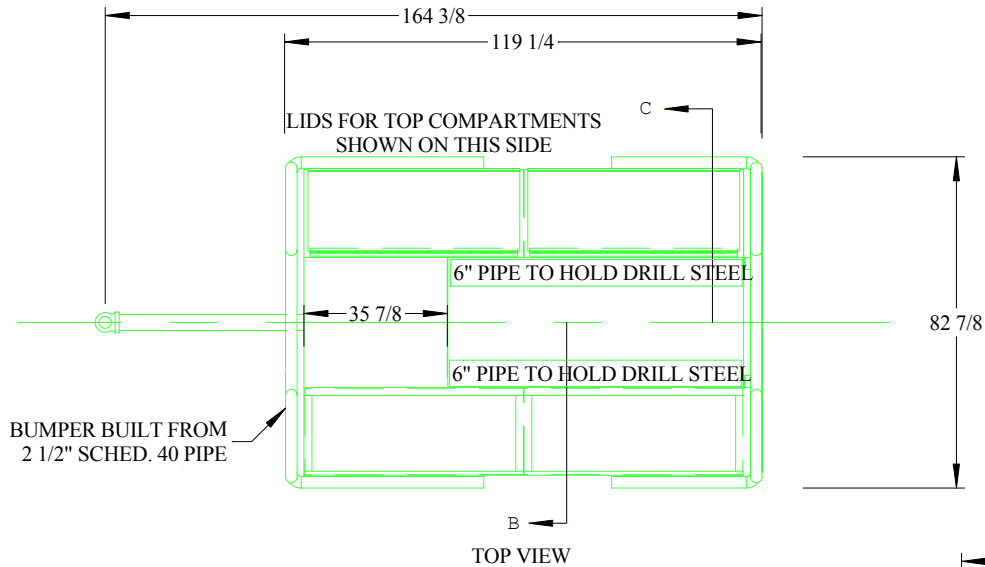

*Uintah Machine & Mfg. Co.*

P.O. Box 8  
Duchesne, UT, 84021

Phone 435 738-2453  
Fax 435 738-2506

TOOL TRAILER FOR SOLVAY

GENERAL ARRANGEMENT

DATE: 10/27/00 DRAWN BY: Bryce Hamilton SCALE: 48 : 1

PATH, FILE NAME, OR DRAWING NUMBER TRAILER1.TCW

worecord\beg19000\19241dir\trailer1.tcw

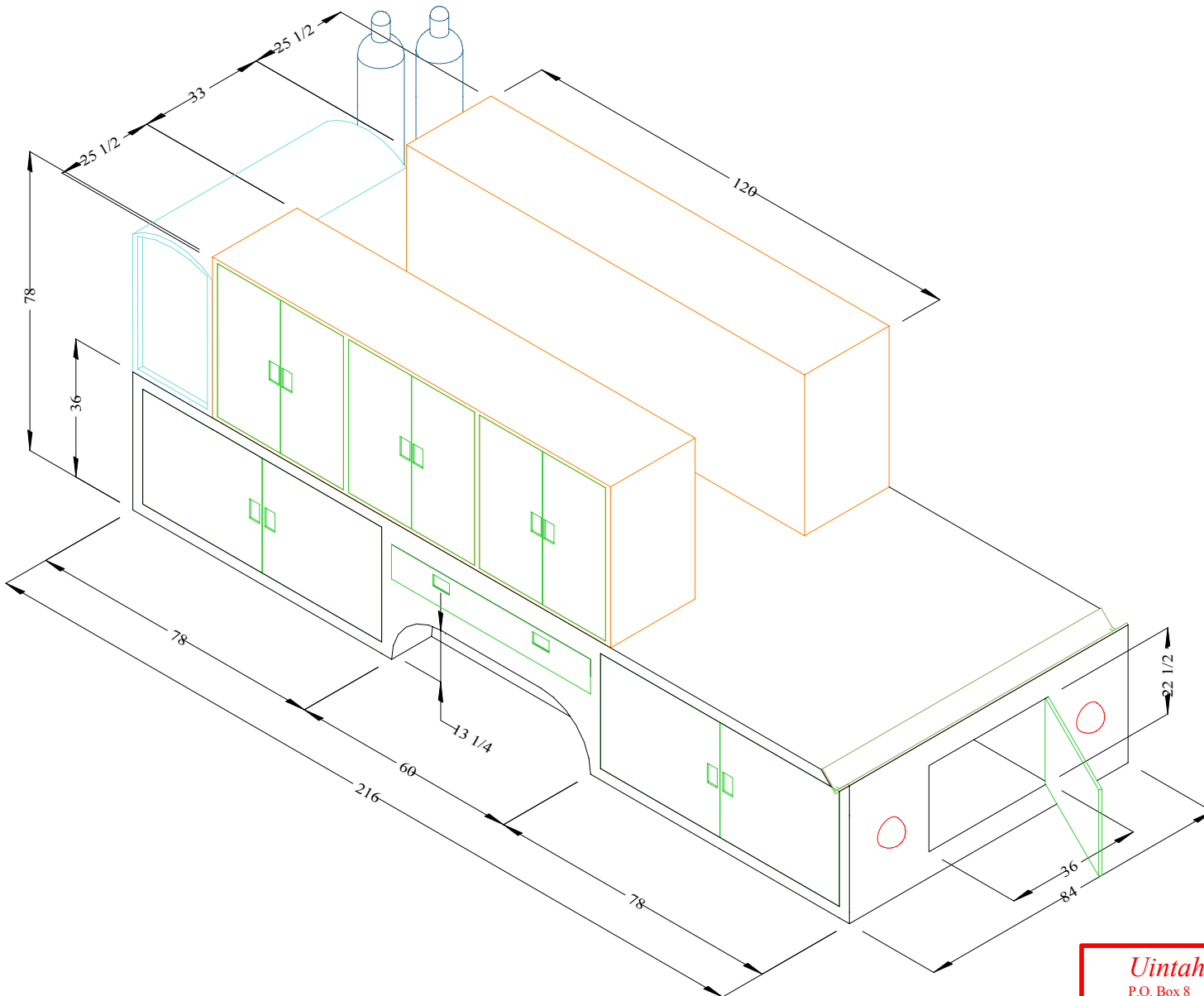

*Uintah Machine & Mfg. Co.*

P.O. Box 8  
Duchesne, UT. 84021

Phone 801 738-2453  
Fax 801 738-2506

CONCEPTUAL DRAWING: MECHANIC'S TRAILER

DATE: Computerized 01/11/01	DRWN BY: Jake Hamilton	SCALE: NTS
PATH, FILE NAME, OR DRAWING NUMBER		00457-01.TCW

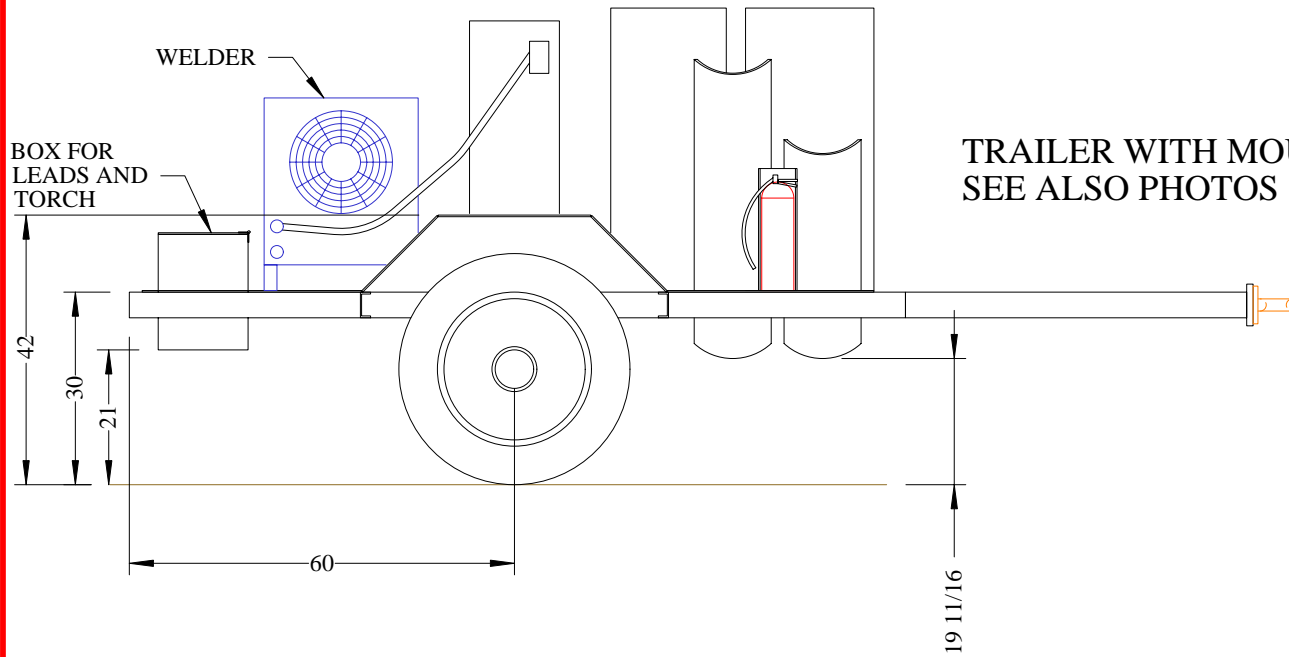
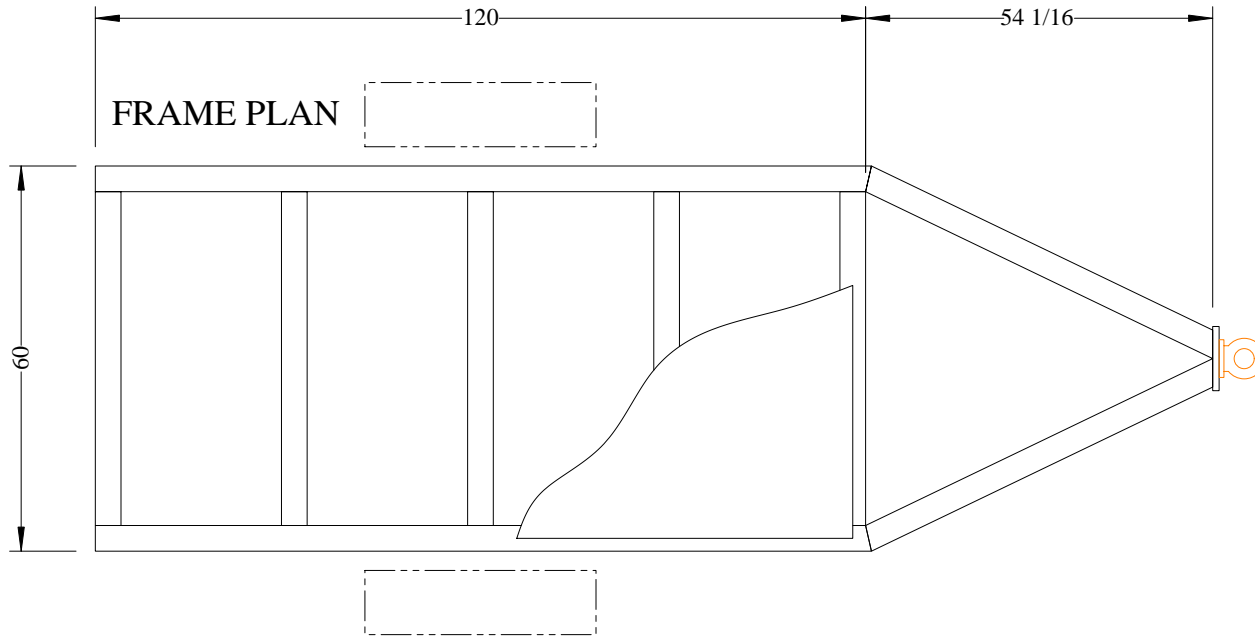

<b>Uintah Machine &amp; Mfg. Co.</b>		
P.O. Box 8		Phone 435 738-2453
Duchesne, UT. 84021		Fax 435 738-2620
TOOL TRAILER WITH SMALL ELECTRIC WELDER FOR SKYLINE		
DATE: 03/15/03	DRWN BY: Jake Hamilton	SCALE: 1: 30
PATH, FILE NAME, OR DRAWING NUMBER:		19363-01.TCW

BEG19750\19363DIR\19363-01.TCW



WELDER AND TOOL TRAILER

TOOL TRAILERS



WELDER AND TOOL TRAILER

TOOL TRAILERS