

Measure Your Lathe. Fill in the data below.
 Uintah Machine & Mfg. Co.
 P. O. Box 8
 Duchesne, Utah 84021

Fax or mail it in for a Price and Delivery.

email to: sales@uintahmachine.com
 Phone (435) 738-2453
 fax: (435) 738-2506 or 738-2620

From: _____

Your Email Address: _____
 Your Phone #: _____
 Your Fax #: _____

Make of Lathe: _____
 Serial No.: _____
 Model No.: _____
 Capacity Needed: _____

Swing Over Ways: _____
 Swing Over Cross Slide: _____
 Weight of Workpiece: _____
 Measured By: _____

DRAWING FR

FOR FOLLOWER RESTS

- A _____
- B _____
- C _____
- D _____
- E _____
- F _____
- G _____
- K _____

MAKE OF LATHE _____
 MODEL & SERIAL NO. _____
 SWING OF MACHINE _____
 SWING OVER CROSS SLIDE _____
 DIAMETER OF WORK _____
 OPTIONS: BRASS OR ROLLERS
 3 JAWS OR 2 JAWS
 JAWS ON RIGHT SIDE OR LEFT SIDE

OPERATOR SIDE

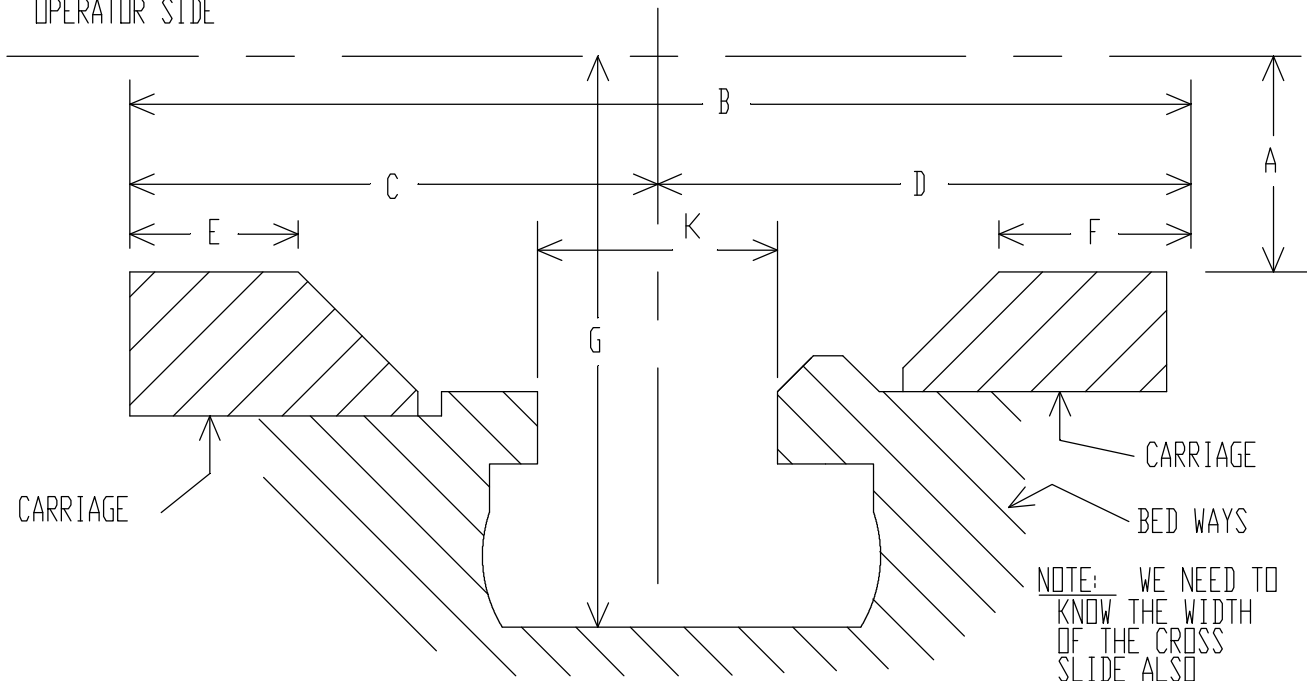

DRAWING # FR_0600